



BLT 5A-120A/W Bolaite Screw Air Compressor

Energy-saving and reliable
air compressors with
excellent performance.



Better Life Together

www.bolaiteaircompressor.com

History

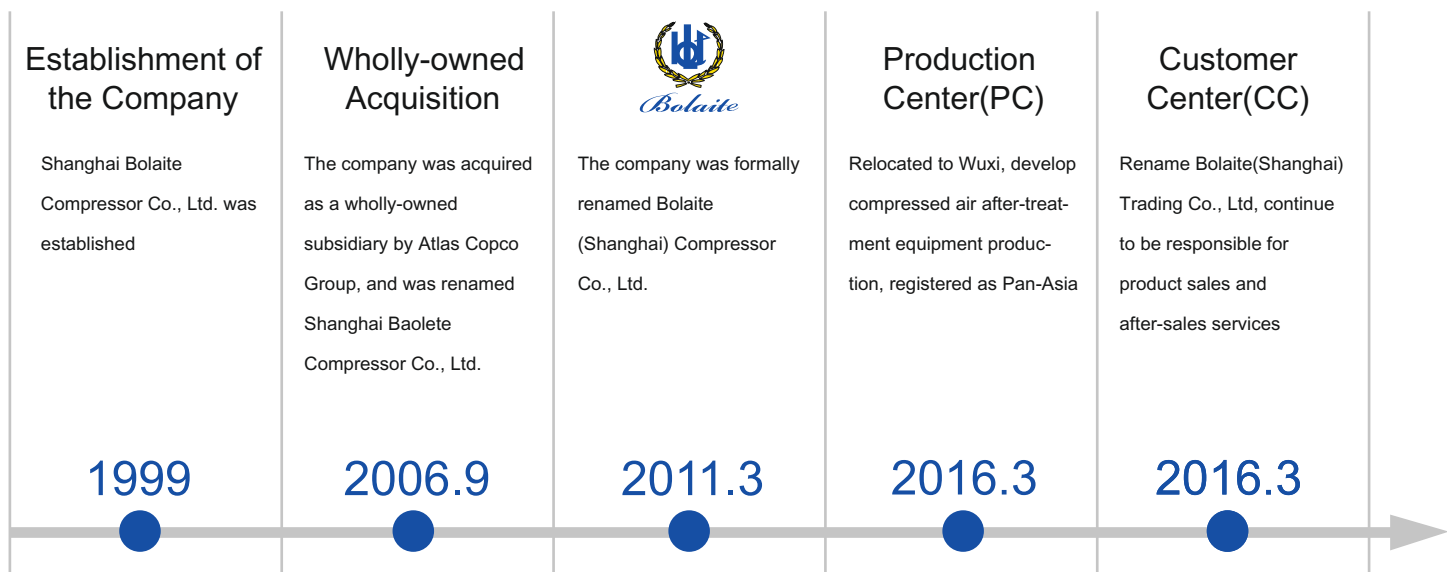

About Bolaite

Bolaite is a company specialized in the design, manufacturing and sale of screw air compressors. Through years of effort, Bolaite brand products have been sold all over the country, have entered a large number of application fields and have won wide recognition and praise from the market. Bolaite has acquired the ISO90001 authoritative certification of Lloyd's (UK) and has obtained various international certifications in environmental protection, safety and electrical engineering. All which makes Bolaite become one of the leaders in air compressor industry in China.

In March 2016, according to Atlas Copco group development strategy in the Chinese market, the production center of Bolaite was relocated to Wuxi, and after the expansion of the compressed air after-treatment equipment production business, a new production base, Pan Asia Gas Technology (Wuxi) Co., Ltd., was established.

Bolaite customer center was renamed Bolaite (Shanghai) Trading Co., Ltd. and continues to be responsible for the sales and service business of Bolaite in Shanghai.

Bolaite has continuously launched new air compressors and compressed air after-treatment products according to the market demand, and will pay attention to safety and energy-saving requests, so as to become a long-term, stable and responsible partner to its customers and collaborators. Just as Bolaite brand commitment says, "Better Life Together".





Advanced compressor R&D management system

- Bolaite product design has introduced the advanced R&D and management system of the group company.
- Each new product needs to go through five stages and more than one thousand processes before it can be serialized.



Advanced standard manufacture management method from group company

- Reasonable process arrangement;
- quality traceability and responsible person system;
- the process and quality of each process are controlled.

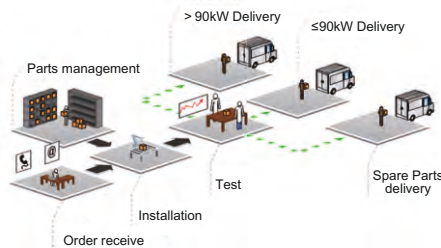

Rigorous factory test procedure

- Each compressor must undergo rigorous testing before leaving the factory and have an independent quality inspection department to monitor the quality.



Compressor Maintenance

Bolaite offers a comprehensive range of maintenance services tailored to your equipment, from a single price to a long-term parts supply or a preventive maintenance contract. Through above contracts, you can enjoy value-added original service and protection, as well as price-competitive parts diagnosis and update.

We also provide energy saving solutions such as energy recovery, frequency conversion, energy saving optimization systems, etc., which can greatly reduce your production costs.



Original spare parts and anti-counterfeiting

All Bolaite original spare parts have undergone laboratory tests and on-site endurance tests to demonstrate that they meet specific technical requirements under all conditions. Only the use of original Bolaite spare parts can guarantee the stability and reliability of the operation of the air compressor. Once interrupted, it will seriously threaten the normal operation of the air compressor, which will affect the user's production schedule, production quality and operational efficiency.

Bolaite original spare parts identification method

Tel: 800-820-5199

Text message: 106695882108

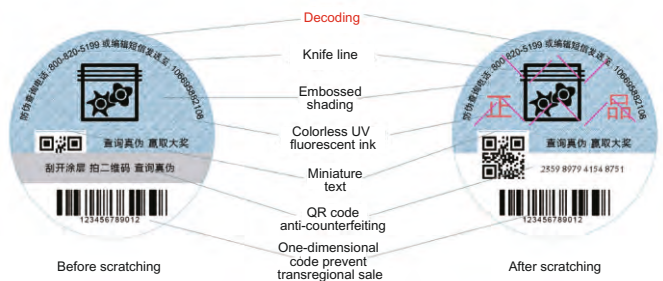

Excellent Energy Efficiency, Stable Performance

BLT 5A-120A/W Screw Air Compressor

- Benefited from more than 140 years of historical heritage and technical experience.
- Utilizing the outstanding design capabilities and rich experience of the European Group's headquarters in air compressors, following the strict development process and testing standards of the European Group, the company has strengthened the design of various complex climates and poor working conditions in China to ensure each BLT series compressor provides the most reliable quality assurance.



High quality core components

- The screw rotor is like the heart of a screw compressor. Its performance directly affects the energy efficiency and service life of the whole machine. Bolaite uses the Atlas Copco rotor which is the leading rotor in compressor field.
- The SAP patented line maximizes screw compression efficiency and saves more than 5% energy compared to similar products on the market.
- The processing precision is high, the host vibration is small, and the noise is low.
- SKF heavy-duty bearings, high-rigidity rotors ensure long-life and reliable operation.



Intelligent control system

- LCD display in English and Chinese, the interface is friendly and intuitive, and the unit parameters can be adjusted quickly and conveniently.
- Powerful all-round protection: minimizes short-circuit, blockage, phase loss, overload, etc.
- A variety of signal outputs: switch analog / RS-485 port, optional large-screen touch master.



Electrical system

- Standardized design, safe and reliable;
- Specialized wiring interface, reasonable wiring, concise, clear and conducive to maintenance;
- Schneider and Siemens high-grade series components, long-term security for safe use.





Patented modular design

- The power <37KW model features a patented and innovative modular design that integrates high-efficiency rotors, valve components, main lines and oil and gas separation systems with no leakage, low pressure loss and easier maintenance. The groundbreaking patented technology creates the extremely high operating efficiency and reliability of the unit.

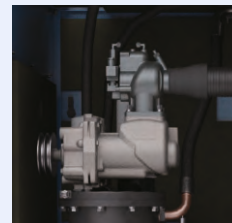

High Quality Motor

- Efficient design, SKF bearings ensure long life of the motor.
- IP54 protection fully enclosed motor, can also run without worry under the dusty conditions.
- Standard phase sequence protection prevents reverse rotation.



Efficient Cooler

- Large oil cooler design: Even in high temperature, dusty environment the cooler can keep the temperature of lubricating oil in normal range, ensuring the safety of the compressor through summer.

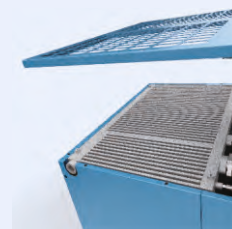

Preventive filter protection cover

- Unique preventive filter cover design, keep the whole machine clean, extend maintenance cycle, easy to disassemble and clean, and can be reused.



BLT series 5 A-120 A/W technical parameters

Model	Pressure bar	Capacity FAD m ³ /min	Motor kW	Dimensions LxWxH mm	Weight kg	Air outlet
BLT-5A	8.5	0.58	4	650x650x890	P/TM/TMDD	G1/2"
	10.5	0.51		1547x650x1473 TM/TMDD	152/296/316	
BLT-7A	8.5	0.82	5.5	650x650x890	P/TM/TMDD	G1/2"
	10.5	0.68		1547x650x1473 TM/TMDD	166/304/333	
BLT-10A	8.5	1.13	7.5	650x650x890	P/TM/TMDD	G1/2"
	10.5	0.9		1547x650x1473 TM/TMDD	175/319/368	
BLT-15A	7.5	1.79	11	850x790x1260 1520x788x1775 TM 1537x790x1784 TMDD	P/TM/TMDD	G1" G3/4" TM G1" TMDD
	8.5	1.78				
	10.5	1.36				
	13	1.19				
BLT-20A	7.5	2.3	15	850x790x1260 1520x788x1775 TM 1537x790x1784 TMDD	P/TM/TMDD	G1" G3/4" TM G1" TMDD
	8.5	2.2				
	10.5	2.0				
	13	1.5				
BLT-25A	7.5	3.0	18.5	850x790x1260 1520x788x1775 TM 1537x790x1784 TMDD	P/TM/TMDD	G1" G3/4" TM G1" TMDD
	8.5	3.0				
	10.5	2.6				
	13	2.1				
BLT-30AG	7.5	3.7	22	1150x850x1000	436	G1"
	8.5	3.5				
	10.5	3.0				
BLT-30A	13	2.4		850x790x1260	380	
BLT-40AG	7.5	5.4	30	1430x950x1200	559	G1 1/2"
	8.5	5.0				
	10.5	4.5				
BLT-50AG	7.5	6.2	37	1430x950x1200	614	G1 1/2"
	8.5	6.1				
	10.5	5.1				

Model	Pressure bar	Capacity m ³ /min	Motor kW	Dimensions LxWxH mm	Weight kg	Air outlet	Water in/outlet
BLT-60AG	7.5	8.4	45	1720x980x1600	870	G1 1/2"	-
	8.5	8.0					
	10.5	7.4					
	13	6.4					
BLT-75AG/WG	7.5	10.5	55	1950x1060x1600 AIR 1819x1060x1596 WATER	1220 AIR 1250 WATER	G2" AIR G1 1/2" WATER	G1"
	8.5	10.0					
	10.5	9.1					
	13	7.8					
BLT-100AG/WG	7.5	13.6	75	1950x1060x1600 AIR 1819x1060x1596 WATER	1285 AIR 1300 WATER	G2" AIR G1 1/2" WATER	G1"
	8.5	13.0					
	10.5	11.8					
	13	10.3					
BLT-120A/W	7.5	17.1	90	2260x1060x1600 AIR 1819x1060x1596 WATER	1570 AIR 1620 WATER	G2" AIR G1 1/2" WATER	G1"
	8.5	17.0					
	10.5	15.2					
	13	12.5					
BLT-120A/W VFC	7.5	3.4-17.1	90	2260x1060x1600 AIR 2557x1060x1596 WATER	1650 AIR 2060 WATER	G2" AIR Dn65 WATER	G1"
	8.5	3.4-17.0					
	10.5	3.0-15.2					
	13	2.5-12.5					

Note : 1. A-air cooling W-water cooling

2. P-floor mounted without tank or dryer

TM-compact machine with air receiver

TMDD-compact machine with air receiver and refrigerated dryer

3. Air receiver volume : BLT-5A TM: 200L

BLT-7A TM: 250L

BLT 10-25A TM: 270L





Inverter-driven: Energy Saving Control

The energy cost of air compressor typically accounts for about 82% of the total cost during the lifecycle, with the power cost possibly over 40% of the total electricity fee of the factory. As proved by a long-term tracking study, the demand of most users for compressed air fluctuates dramatically by 40%-80% at different time.

Bolaite's advanced VFC variable Air Compressor can precisely meet users' demand for compressed air. When the air consumption is reduced, the rotary speed is lowered, the displacement is correspondingly less, and the power consumption is proportionally decreased. Through the advanced inverter technology, the unloading time of the compressor, and thus the power consumption is remarkably reduced.

Lifecycle Cost of Conventional Compressors

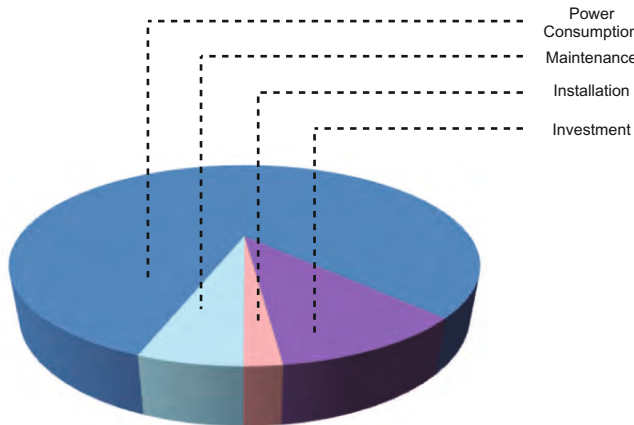

Lifecycle Cost of VFC Inverter Air Compressors

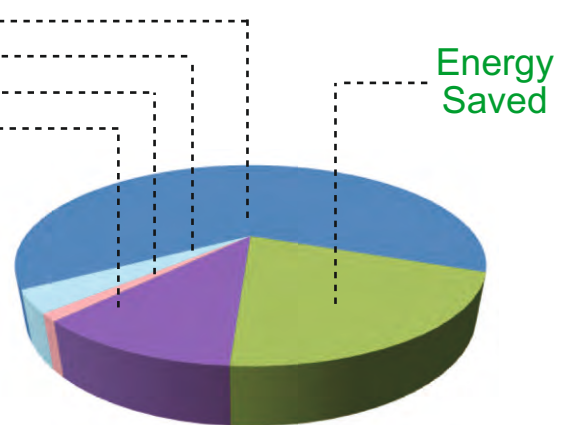

The average power consumption could be reduced by 30% even more

Bolaite variable speed air compressor can automatically adjust rotary speed of the motor by tracking the change of air demand, so the average power consumption is reduced by 30% even more. The extra investment cost for variable speed air Compressor can be recovered in one to two years.

Fix Speed Air Compressor: High Cost to Cope with Fluctuating Air Demand

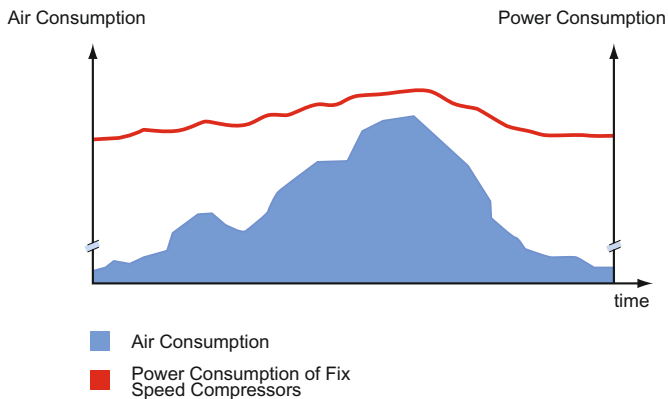

Variable Speed Air Compressor: Variable Air Flow and Energy-saving Control

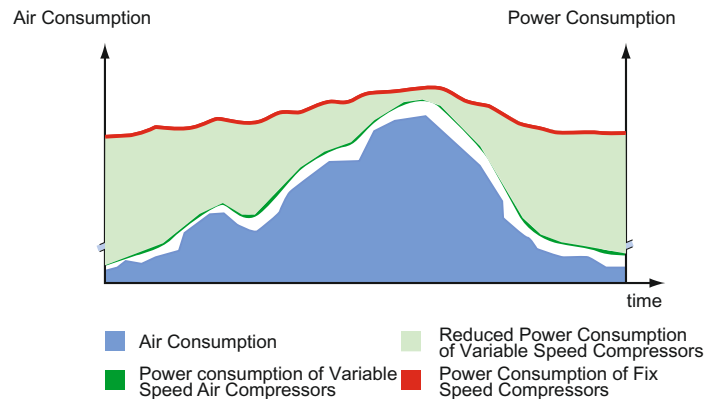

Conventional air compressors cope with fluctuating air demand by setting a wide range of air pressure, loaded when the air demand is high and unloading when the air demand is low. Therefore, the system pressure, and thus the power consumption is high. Due to the fluctuating air demand, the compressor is in unloading state for relatively a long time, which leads to energy waste.

The working pressure set for the variable speed air compressor is the pressure required by the customer, and the whole system is running at a lower pressure. As the rotary speed of the motor can be changed to meet the low air demand of the customer, the compressor is seldom unloading, and thus has no unnecessary power consumption.

The perfect combination of rotor and high efficiency permanent magnet motor

▶▶▶ BLT OPM+ permanent magnet inverter compressor

The perfect combination of the newly-launched Atlas Copco mainframe and high-efficiency permanent magnet motor, mature split-type direct-coupled drive system, no integrated permanent magnet inverter compressor, inconvenient disassembly, easy demagnetization and other disadvantages, the pursuit of extreme efficiency At the same time, the compressor is guaranteed to be highly reliable.



New rotor

- The Atlas Copco rotor specially developed for inverter technology, maintains high efficiency over a wide frequency range and meets National Level 1 energy efficiency standards in the main frequency range.



Permanent magnet high efficiency motor

- IP55 protection fully enclosed motor to prevent the dust from being attracted by the motor magnet
- No electrical excitation start
- High grade magnetic steel, 180 °C temperature resistance
- IE3 energy efficient motor

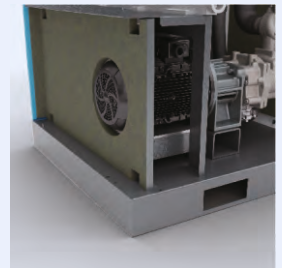

Large Touch Controller

- Matching drive exclusive customization
- LCD display in Chinese and English
- Self-diagnosis function such as fault report, maintenance reminder, automatic shutdown, etc.
- Clock function, can set the timer switch machine
- Multiple signal outputs: RS485 port

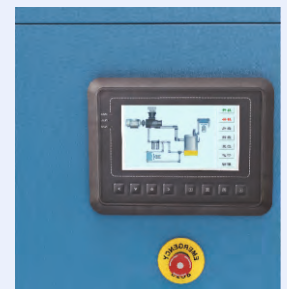

Direct drive

- 1:1 direct drive, stable and efficient
- More mature split-type direct drive, more reliable and easier to maintain than integrated drive
- Imported brand, large size coupling to ensure long life of the drive system



High efficiency oil cooled permanent magnet motor

Newly developed airend

- Installed Atlas Copco airend which specially developed for inverter technology, maintains high efficiency over a wide frequency range and reaches highest energy efficiency



Oil cooled PM motor

- Ie4 super high efficient oil cooled PM motor for highest energy efficiency
- Oil cooled PM motor, no demagnetization risk
- Ip66 high protection rate
- Patented design of vacuum oil return device



Patented drive chain

- Atlas Copco designed drive chain with high efficient and longer service life
- Three sets of SKF bearing for safe operation
- 1:1 direct drive, stable and efficient

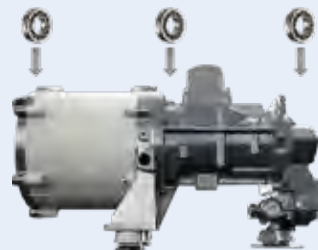

Customized Inverter

- Optimum current vector control
- Special designed for air compressor system
- Range from 15Hz to 50Hz
- Improved cooling system for stable

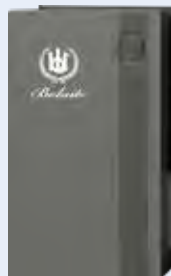



Model	Pressure bar		Capacity m3/min	Motor kW	Dimensions LxWxH mm	Weight kg	Air outlet
	Min.	Max.					
BLT-10A OPM+	6	10.5	0.19-1.15	7.5	850x750x1000	205	G3/4"
BLT-15A OPM+	6	10.5	0.27-1.72	11	850x750x1000	205	G3/4"
BLT-20A OPM+	6	10.5	0.5-2.1	15	850x750x1000	205	G3/4"
BLT-25A OPM+	6	10.5	0.6-3.3	18.5	950x850x1080	280	G1"
BLT-30A OPM+	6	10.5	0.7-3.7	22	950x850x1080	290	G1"
BLT-40A OPM+	6	10.5	1.4-5.3	30	1130x950x1200	362	G1 1/2"
BLT-50A OPM+	6	10.5	1.8-6.4	37	1130x950x1200	416	G1 1/2"
BLT-60A OPM+	6	10.5	1.7-8.5	45	1723x980x1600	755	G1 1/2"
BLT-75A OPM+	6	10.5	1.8-11.0	55	1920x1060x1600	920	G2"
BLT-100A OPM+	6	10.5	2.6-13.1	75	1920x1060x1600	980	G2"

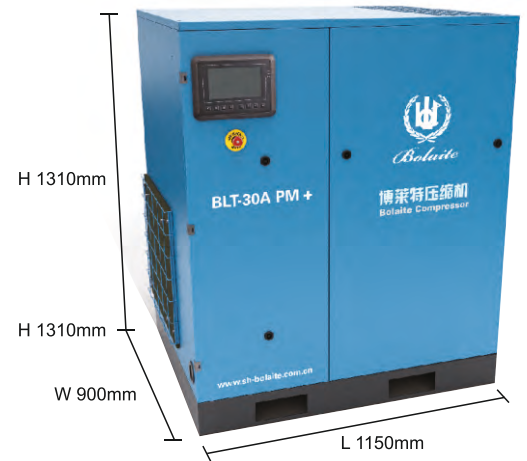

Cooling oil flow chart

1. Low temp. cooling oil adsorb heat from motor shell, no cooling fan needed for motor
2. Oil then pass through airoend, adsorb heat from airoend,

Flow chart

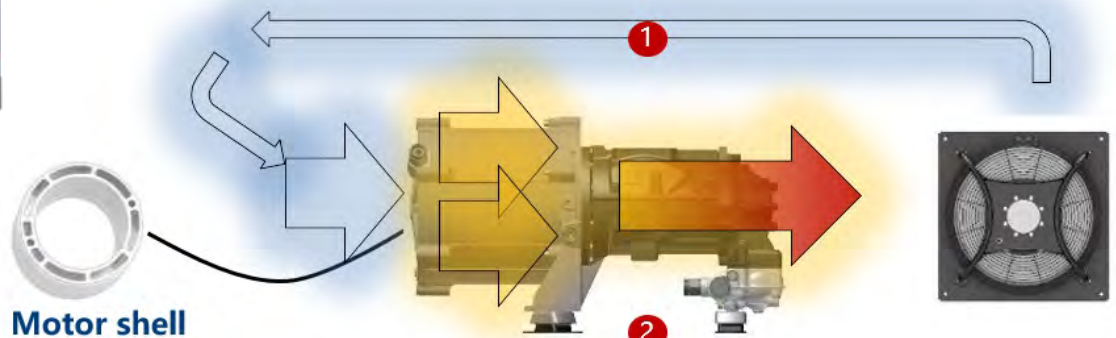

First-class energy efficiency, a hundred years of inheritance



1

BLT-S ultra-efficient series air compressor



Bolaite

National First-class energy efficiency

Bolaite BLT-S uses 0.115 degrees of electricity per cubic air be compressed 6.9 SER 6.9 (kW·min/m³)

2

Energy efficiency savings than National second-class energy efficiency

20%

National second-class energy efficiency uses 0.135 degrees of electricity per cubic air be compressed 8.1 SER 8.1 (kW·min/m³)

3

Energy efficiency savings than National third-class energy efficiency

30%

National third-class energy efficiency uses 0.147 degrees of electricity per cubic air be compressed 8.8 SER 8.8 (kW·min/m³)

For example BLT-60AG S/8bar 45kW)

1/2/3-class energy consumption comparison

power	Pressure	Electricity degree uses per cube air			Full load 4000 hours electricity use	
	MPa	First-class	Second-class	Third-class	saving more than second-class energy	saving more than third-class energy
30	0.8	0.120	0.135	0.147	20,000	35,000
37	0.8	0.120	0.135	0.147	24,000	43,000
45	0.8	0.120	0.135	0.147	30,000	54,000
55	0.8	0.108	0.122	0.138	33,300	75,000
75	0.8	0.108	0.122	0.138	45,000	102,000

BLT-S ultra-efficient series air compressor

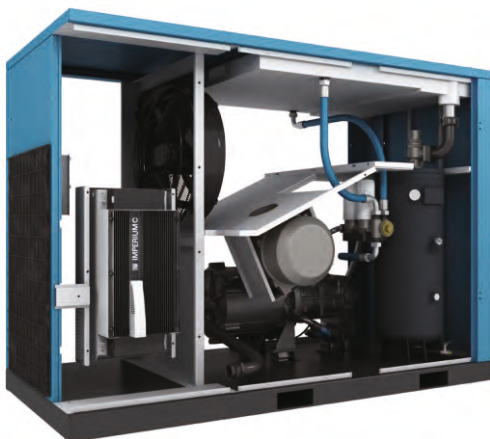

- All Bolaite BLT S ultra-efficient series compressors achieve national first-class energy efficiency, which is about 20% more energy efficient than second-class energy efficiency, 30% than third-level energy efficiency.
- Atlas Copco's high-efficiency rotor delivers higher efficiency, lower noise and longer life.
- 7-inch large-screen color display controller: support Chinese and English switching / RS485 port.
- Vacuum inlet valve, reducing pressure loss, less moving parts, no elastic parts such as springs, energy saving and reliable.
- BLT S VFC series is equipped with variable frequency motor and unique vector frequency conversion technology to ensure rapid conversion of the whole machine.
- BLT S PM+ series is equipped with IE4 high-efficiency oil-cooled permanent magnet motor. The motor adopts a new high-grade magnetic steel with no demagnetization risk. The configuration adopts the patented inverter and main controller developed by Atlas Copco group for air compressors to ensure the whole machine reliability and excellent energy efficiency.



BLT S PM+ oil-cooled permanent magnet inverter compressor

The whole machine adopts a complete set of Atlas Copco oil-cooled permanent magnet frequency conversion technology: The Group independently develops oil-cooled permanent magnet motor, frequency converter and controller to ensure the reliability of the whole machine and further save energy by 7%.



New Rotor

- The newly developed Atlas Copco rotor maintains efficient operation over a wide frequency range and meets national first-class standards within the main frequency range.



Oil-cooled permanent magnet high efficiency motor

- Ip66 protection fully enclosed motor, prevent the dust from being absorbed by the motor magnet
- Adopting a new generation of permanent magnet samarium cobalt, 350°C temperature resistance, no demagnetization risk
- IE4 energy efficient motor, motor efficiency up to 96-97%
- All aluminum shell coating, oil cooling, high cooling efficiency, and no fan noise



Independent research and development of intelligent control system

- Atlas Copco Group develops for air compressor applications
- CSA and UL standards, strict quality standards to ensure reliable operation
- CANbus communication port application for faster data transfer and better electromagnetic compatibility



Imperium frequency converter

- Developed by Atlas Copco Group independently and has been widely verified worldwide.
- IP5X protection, surrounded by an overall aluminum shell
- Built-in EMC to eliminate harmonic external interference
- Compact structure, high power density, more than 35% inverter configuration capacity



BLT S ultra-efficient series 40AG S-100AG/WG S technical parameters

Model	Pressure bar	Capacity m ³ /min	Motor kW	Dimensions LxWxH mm	Weight kg	Air outlet	Water inlet/outlet
BLT-40AG S	7.5	5.9	30	1720x980x1600	820	G1 1/2"	-
	8.5	5.5					
	10.5	5.0					
	13	4.2					
BLT-50AG S	7.5	7.2	37	1720x980x1600	850	G1 1/2"	-
	8.5	6.7					
	10.5	6.1					
	13	5.1					
BLT-60AG S	7.5	8.4	45	1720x980x1600	950	G1 1/2"	-
	8.5	8.4					
	10.5	7.8					
	13	6.2					
BLT-75AG/WG S	7.5	11.1	55	2260x1060x1600 AIR 1819x1060x1596 WATER	1460 A 1480 W	G2" A G1 1/2" W	G1"
	8.5	10.4					
	10.5	9.2					
	13	7.9					
BLT-100AG/WG S	7.5	14.9	75	2260x1060x1600 AIR 1819x1060x1596 WATER	1535 A 1550 W	G2" A G1 1/2" W	G1"
	8.5	14.1					
	10.5	12.6					
	13	10.6					

Model	Pressure bar		Motor kW	Capacity m ³ /min	Dimensions LxWxH mm	Weight kg	Air outlet
	Min.	Max.					
BLT-10A S PM+	6	13	7.5	0.29-1.20	1100x850x1080	230	G3/4"
BLT-15A S PM+	6	13	11	0.38-1.81	1100x850x1080	231	G3/4"
BLT-20A S PM+	6	13	15	0.5-2.2	1100x850x1080	241	G3/4"
BLT-25A S PM+	6	13	18.5	0.7-3.4	1250x950x1180	313	G1"
BLT-30A S PM+	6	13	22	0.7-3.8	1250x950x1180	321	G1"
BLT-40A S PM+	6	13	30	1.4-5.7	1330x950x1200	412	G1 1/2"
BLT-50A S PM+	6	13	37	1.9-6.4	1330x950x1200	413	G1 1/2"
BLT-60A S PM+	6	13	45	1.6-8.6	1723x980x1600	733	G1 1/2"
BLT-75A S PM+	6	13	55	1.6-11.4	2210x1060x1600	932	G2"
BLT-100A S PM+	6	13	75	1.7-13.3	2210x1060x1600	973	G2"
BLT-100A S PM++	6	13	75	3.3-15.4	2254x1060x1600	1020	G2"
BLT-120A S PM+	6	13	90	3.8-18.0	2254x1060x1600	1040	G2"

Note : 1. S PM+ : ultra efficient OPM motor
 2. S PM++ : ultra efficient plus OPM motor
 3. Max. capacity at 7bar





BLD series

pressure dew point 3-7°C
outlet relative humidity as low as 10%

* Standard hot gas bypass valve and electronic timing drain valve



BLR series

pressure dew point 3-10°C
outlet relative humidity as low as 20%



Provides drier compressed air

- High-efficiency three-in-one plate-fin heat exchanger: inlet and outlet temperature difference as low as 5 °C
- High efficiency water separator: water removal efficiency of 99%
- Outlet compressed air relative humidity as low as 20%



More energy saving

- 50% lower energy consumption than cold-dryers with shell-and-tube heat exchangers
- Efficient R410A environmentally friendly refrigerant agent



More reliable

- Industrial-grade brand refrigeration compressor
- New smart display with dew point display and fault alarm in one
- Optimized piping design with only 4 individual welds for less risk of leakage
- Each machine is tested for leak detection of compressed air, helium and refrigerant before leaving the factory.

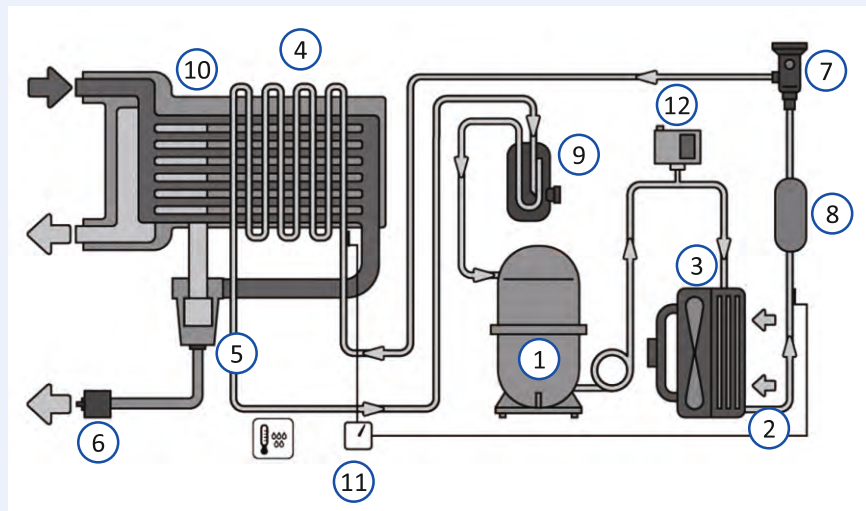

- | | | |
|----------------------------|------------------------|----------------------------------|
| ① refrigeration compressor | ② air-cooled condenser | ③ motor fan |
| ④ evaporator | ⑤ gas-water separator | ⑥ drain valve |
| ⑦ expansion valve | ⑧ drying filter | ⑨ gas-liquid separator |
| ⑩ air heat exchanger | ⑪ dew point display | ⑫ high voltage protection switch |

BLD series technical parameters

Model	Capacity m ³ /min	Refrigent	Power kW	Legnth(L) mm	Width(W) mm	Height(H) mm	Weight(kg)	Air inlet/outlet
BLD15	1.5	R134a	360	550	370	800	32	G1"
BLD21	2.1	R134a	364	550	370	800	36	G1"
BLD35	3.5	R410A	951	520	500	800	60	G1"
BLD45	4.5	R410A	988	550	600	980	68	G1 1/2"
BLD60	6.0	R410A	1000	550	600	980	75	G1 1/2"
BLD75	7.5	R410A	1125	550	600	980	85	G2"
BLD90	9.0	R410A	1674	900	750	1000	120	G2"
BLD115	11.5	R410A	1700	1025	660	1120	130	G2 1/2"
BLD150	15.0	R410A	1900	1025	660	1120	135	G2 1/2"
BLD175	17.5	R410A	2220	1025	660	1120	150	G2 1/2"
BLD225	22.5	R410A	2610	1025	660	1120	155	G2 1/2"
BLD250	25.0	R410A	2950	1025	660	1120	180	G2 1/2"

Model	Capacity m ³ /min	Refrigent	Power kW	Legnth(L) mm	Width(W) mm	Height(H) mm	Weight(kg)	Air inlet/outlet
BLR10	1.0	R134a	217	352	430	445	30	G3/4"
BLR13	1.3	R134a	360	550	370	704	30	G1"
BLR21	2.1	R134a	364	550	370	704	34	G1"
BLR40	4.0	R410A	700	520	500	809	55	G1"
BLR66	6.6	R410A	951	520	500	809	60	G1 1/2"
BLR85	8.5	R410A	988	550	600	958	68	G1 1/2"
BLR105	10.5	R410A	1000	550	600	958	75	G2"
BLR140	14.0	R410A	1674	900	750	1009	110	G2"
BLR175	17.5	R410A	1750	795	758	1021	130	G2"
BLR220	22.0	R410A	2850	793	932	1128	133	G2 1/2"
BLR260	26.0	R410A	3000	793	932	1128	140	G2 1/2"

- Ambient temperature: ≤45°C
- Inlet temperature: ≤60°C
- Maximum inlet pressure: BLD15-225/BLR10-260: 13bar BLD270-1050: 10bar
- Power supply: BLD15-225/BLR10-260: 230V/1/50Hz BLD270-1050: 380V/3/50Hz

Correction factor

Ambient temperature	°C	30	35	40	45			
		1	0.91	0.81	0.72			
Inlet temperature	°C	30	35	40	45	50	55	60
		1	1	1	0.82	0.69	0.58	0.49
	bar	6	7	8	10	13		
		0.96	1	1.03	1.08	1.13		

- Design condition: Ambient temperature 30°C, Inlet temperature 40°C
- maximum pressure drop: Below 0.3bar

Air dryer selection example:

The rated gas volume of the compressor is 10m³/min, the actual amount of air to be compressed under the following conditions

- Ambient temperature: 40°C
- Intake air temperature: 40°C
- Intake pressure: 8bar
- Actual amount of processing air required = 10m³/min / 0.81/1/1.03 = 12m³/min

In order to ensure the pressure dew point, it is necessary to select a refrigerated dryer machine with a processing capacity of 12m³/min to meet the actual working

conditions.



▶▶▶ Bolaite high efficiency filter

When the gas is compressed, the dust particles, oil and gas humidity will increase. This produces a corrosive mixture, Serious damage to equipment and even contamination of the final product. In order to save your investment costs and protect equipment and processes, Bolaite offers a complete filtration solution.



Bolaite High Efficiency Filter Features

- Imported multi-layer glass fiber filter, high efficiency decontamination ability, low pressure loss, outstanding filtration effect
- Both inner and outer filter elements are treated with anti-corrosion treatment, stable performance and long service life
- Compact, lightweight, easy to install and maintain
- Provides comprehensive compressed air quality assurance for improved compression system reliability
- BLE series filter comes standard with differential pressure indicator and zero-loss automatic drain valve

Filter technical parameters

For BLD dryer	For BLR dryer	Capacity m ³ /min	Inlet/outlet	Dimensions Length x width x height(mm)	Minimum space required to replace the filter
BLE9	BLF9	0.9	G3/4"	417x106x96	312
BLE18	BLF18	1.8	G3/4"	417x106x96	312
BLE25	BLF25	2.5	G3/4"	417x106x96	367
BLE35	BLF35	3.5	G1"	436x148x121	380
BLE60	BLF60	6.0	G1 1/2"	436x148x121	435
BLE105	BLF105	10.5	G2"	630x180x152	565
BLE140	BLF140	14.0	G2"	630x180x152	600
BLE175	BLF175	17.5	G2"	630x180x152	645
BLE260	BLF260	26.0	G2 1/2"	720x212x190	767
BLE380	BLF380	38.0	G3"	820x240x230	920
BLE490	BLF490	49.0	G3"	990x240x230	

BLE, BLF accuracy level identification

Identification	Filter type	Oil content	Initial pressure drop (bar)
G	Standard Precision Filter	0.1ppm	0.12
C	Super Fine Filter	0.01ppm	0.14
V	Activated Carbon Filter	0.003ppm	0.16

* Install G-class and C-class two-stage filters, can achieve the three-stage filtering effect of similar products in the market.

Reliable, convenient, smart, energy-efficient



- Atlas Copco 16 bar air end for laser cutting application, SKF heavy duty bearings
- Imported high quality filter material and enlarged oil separation system for minimum oil carryover
- Full protection control system protecting equipment from short circuit, phase loss and overloading
- 4 in one full features with air compressor, dryer, filters and air tank in one skid for minimum footprint
- Oil separator system, piping, air tank and filters with 20 bar design pressure for system safety
- Synthetic oil for optimal performance

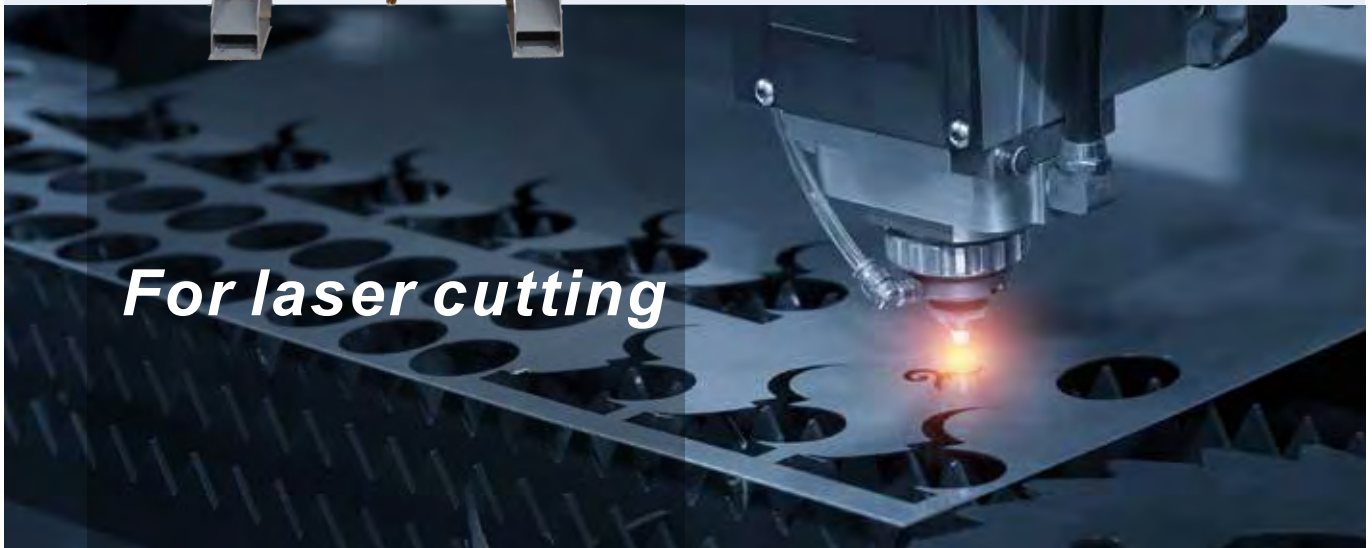

For laser cutting

BLT 15-30A 16 bar technical parameters

Model	Pressure bar	FAD m3/min	Motor kW	Dimensions LxWxH mm	Weight kg	Outlet
BLT-15A	16	0.95	11	740x850x1030 1490x950x1600 TMDD	310 600 TMDD	G3/4" G1/2" TMDD
BLT-20A	16	1.3	15	740x850x1030 1490x950x1600 TMDD	320 600 TMDD	G3/4" G1/2" TMDD
BLT-25A	16	1.75	18.5	740x850x1300 1460x980x1770 TMDD	400 800 TMDD	G1" G1" TMDD
BLT-30A	16	2.1	22	740x850x1300 1460x980x1770 TMDD	410 800 TMDD	G1" G1" TMDD

Note: 1. TMDD – With air tank, dryer, water separator, 3 level line filters
 2. Air tank size: BLT 15-20A : 240L(single tank)
 BLT 25-30A : 300L(double tank)



BLT-series 5A-120A/W
Bolaite Screw
Air Compressor



Care. Trust. Efficiency.

Care.

Care is the base of our services: we offer professional after-sale personnel and high-quality OEM parts.

Trust.

Trust comes from our credible commitments: our products have ever-improving performance and long lifecycle.

Efficiency.

Regular maintenance ensures the efficient operation of our compressors: service efficiency makes a difference in terms of OEM spare parts and service quality.

September 2018 edition, all rights reserved to Bolaite (Shanghai) trading Co., Ltd. All product names, company names, trademarks and service marks referred to herein belong to respective owners. Our products are constantly developing and improving. Therefore, we reserve the right to modify the product specifications at any time without prior notice. All pictures are not binding force to contract.



Contact Local Bolaite Distributors

Service Hotline:

400-8788-851

www.bolaiteaircompressor.com